

Product Technical Information



**SOLAR
SOLVE**
THE ANTI-GLARE EXPERTS

Para más información:
Contacto ANGEL PRIEGO JUSTO S.L.
Tel: +34 986 231873 - +34 678 507644
Email: nifedivon@nifedivon.es
Web: www.nifedivon.es

For safer navigation

Contents

Page 3	Principle On Which SOLASOLV® Film Works
Page 4	Made with SOLASOLV® Technology
Page 5	Measuring Instructions
Page 6	Roller Blinds & Screens / Screen Shapes Available
Page 7 - 8	Operating Systems
Page 8	Double Pulley Bottom Rail Operating System
Page 9	Aluminium Profile Data
Page 10	Spare Parts For Cassette Roller Blinds & Screens
Page 11	Spare Parts For Non-Cassette Roller Blinds & Screens
Page 12	SOLASOLV® Anti-Glare Roller Screen Installation
Page 13 - 14	Installation of Cassette Mounted Blinds & Screens
Page 15 - 16	Installation of Non-Cassette Mounted Blinds & Screens
Page 17	Electrical Operation



Please Note: Images and photographs shown in this brochure may change.

Principle on which SOLASOLV® Film Works

INSTALLATION WITHOUT SOLASOLV® FILM PROTECTION

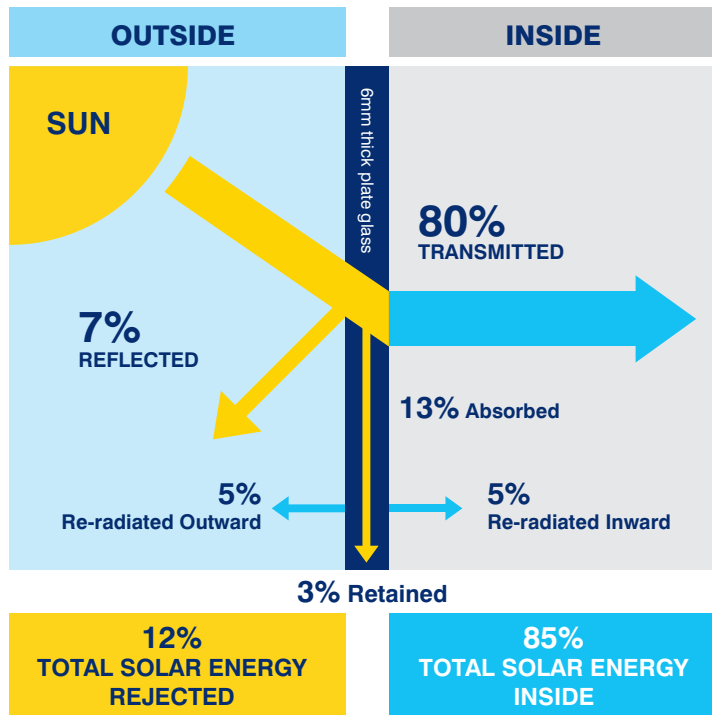

Diagram 1 shows how an enclosed area is heated by the short wave energy from the sun passing through glass windows. This short wave energy is absorbed by the room surfaces and is re-radiated from them as long wave radiation, generating heat in the process.

Because plain glass does not allow this long wave radiation to pass back through it to the atmosphere, the heat is trapped within the enclosed area.

INSTALLATION WITH GOLD SOLASOLV® FILM PROTECTION

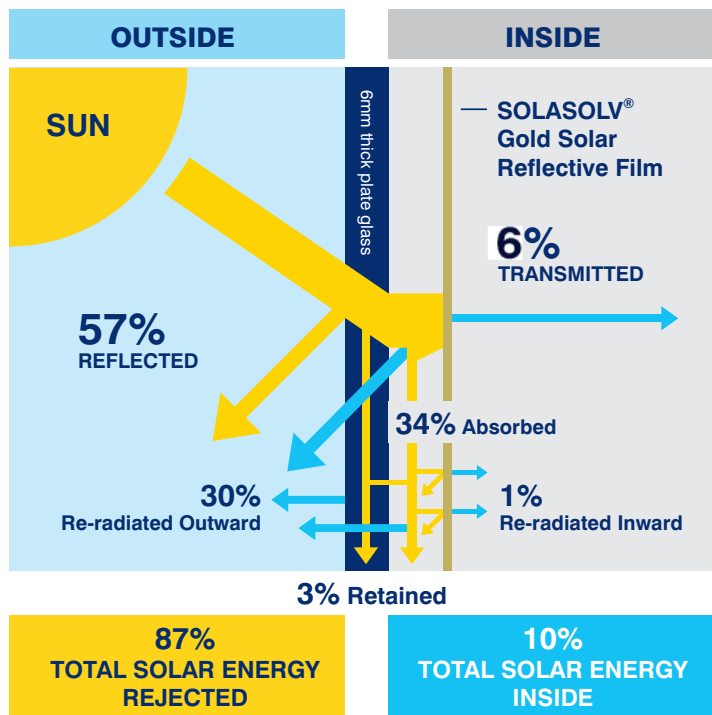

Diagram 2 shows how the rejection of solar energy takes place with very little conversion to heat. The transmitted energy is only converted to heat when it strikes an absorbing surface.

The absorbed heat which is contained in the glass, surroundings and polymer is partly re-radiated to the outside air and partly re-radiated into the inside atmosphere.

The dyed layers of polyester film which make up the finished film type, control the amount of visible light which the film transmits. This feature produces the 'Anti-Glare' effectiveness of the films and the colour shading observed when looking through them.

Made with SOLASOLV® Technology

SPECIFICATIONS FOR SOLASOLV® ROLLER SCREEN FILMS

COLOUR	SOLAR REFLECTIVE			
	GOLD	SILVER	GREY	BRONZE
% Glare Reduction (Anti Glare Effect)	93.2	92.6	91.2	84.1
% Total Solar Energy Rejected (Heat Rejection)	87.2	77.8	65.7	67.6
% Ultra Violet Light Rejected	99.3	97.4	98.6	98.5
% Total Solar Transmission	6	7	20	20
% Total Solar Reflection	48	32	21	22
% Total Solar Absorbtion	46	41	59	58
% Visible Light Transmission	6.1	6.6	7.9	14.2
Shading Coefficient	0.33	0.30	0.60	0.60

The shading coefficient and total solar energy rejected of shade products will vary depending on physical conditions existing at the fitted location. Laboratory conditions for the above tests were for a free hanging system with solar film 15mm from 6mm thick glass.

POLYESTER used in shade films is a biaxially oriented polyethylene terephthalate film.

Heat set during processing, it has a melting point of approx. 260°C (500°F) and does not shrink at temperatures below 150°C.

SOLASOLV® FILM COLOURS AVAILABLE

OUTSIDE IS REFLECTIVE

GOLD		SILVER	
INSIDE	OUTSIDE	INSIDE	OUTSIDE
GREY	GOLD	GREY	SILVER

OUTSIDE IS NON-REFLECTIVE

GREY		BRONZE	
INSIDE	OUTSIDE	INSIDE	OUTSIDE
GREY	GREY	BRONZE	BRONZE

DEFINITIONS FOR SOLAR ENGINEERING PARAMETERS

Total Solar Transmission

The amount of all the sun's energy that goes directly through a glazing system.

Total Solar Reflection

The amount of all the sun's energy that is directly reflected by a glazing system.

Total Solar Absorption

The amount of all the sun's energy that is immediately absorbed by a glazing system.

Total Solar Energy Rejected (Cooling Effect)

The amount of all the sun's energy that is rejected by a glazing system.

Visible Light Transmission

The amount of visible light that goes directly through a glazing system.

Ultraviolet Light Rejected

The amount of all the ultraviolet light that is absorbed by a glazing system.

Glare Reduction (Anti Glare Effect)

The percent reduction in visible light.

Shading Coefficient

A measure of the amount of sun's energy that is allowed through a glazing system. The lower it is, the less total energy goes through and the better the shading.

Measuring Instructions

Always use a metal measuring tape. All blinds/screens are made according to the information and measurements supplied. The manufacturer cannot be held responsible for incorrect information given by a customer.

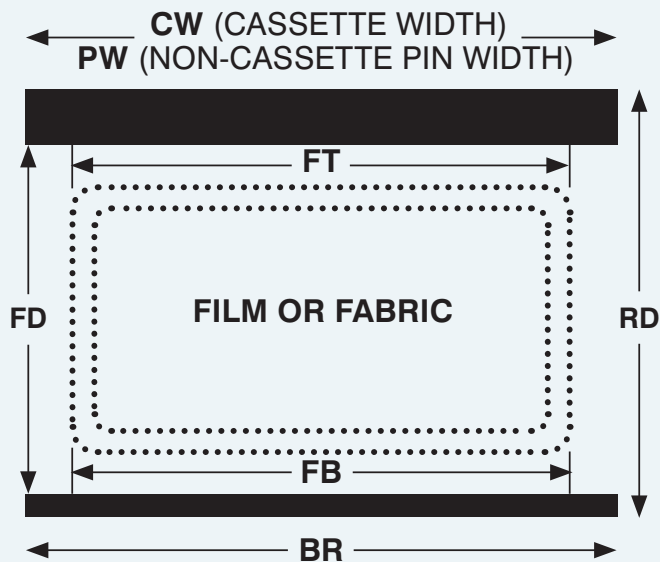

FT = Film / Fabric Top Width
(CW generally 38mm wider depending on operation type)

FB = Film / Fabric Bottom Width
(BR generally 38mm wider depending on operation type)

FD = Film / Fabric Drop

BR = Bottom Rail Width

RD = Required Drop

INSIDE RECESS

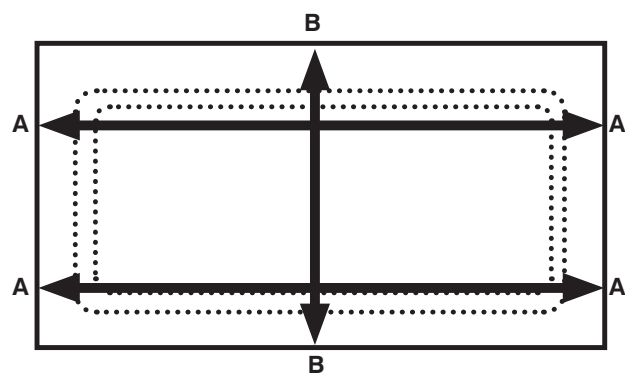

Carefully measure width 'A' at two points to identify the recess and window shape e.g. Square / Rectangular or Tapered. Use the smallest size for 'A'.

Give this as a WIDTH dimension. This is also known as the CW = CASSETTE WIDTH on the SOLASAFE screen or PW = PIN WIDTH on the SOLAROLA screen. Carefully measure the size for 'B' as the DROP dimension. This is also known as the RD = REQUIRED DROP.

OUTSIDE RECESS

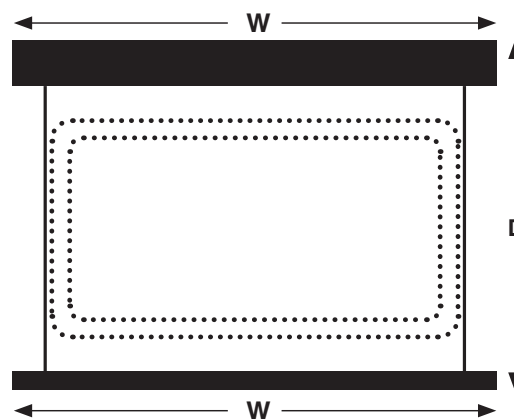

Decide where the blind/screen is to be installed and carefully measure width 'W' and drop 'D'. Give the dimension 'W' as CW = CASSETTE WIDTH or PW = PIN WIDTH and the dimension 'D' as the DROP
'RD' = REQUIRED DROP.

Please Note:

PW is generally 29mm wider than FT, Electric AC is 49mm wider than FT and Electric DC is 44mm wider than FT to allow the material to roll up and down without catching on the cassette or roll tube for these differing mechanism types.

Roller Blinds/Screen Shapes Available

IMPORTANT NOTE:

For unequal tapered screens, either the left hand offset (LHO) or the right hand offset (RHO) as well as the bottom rail width (BR) must be supplied.

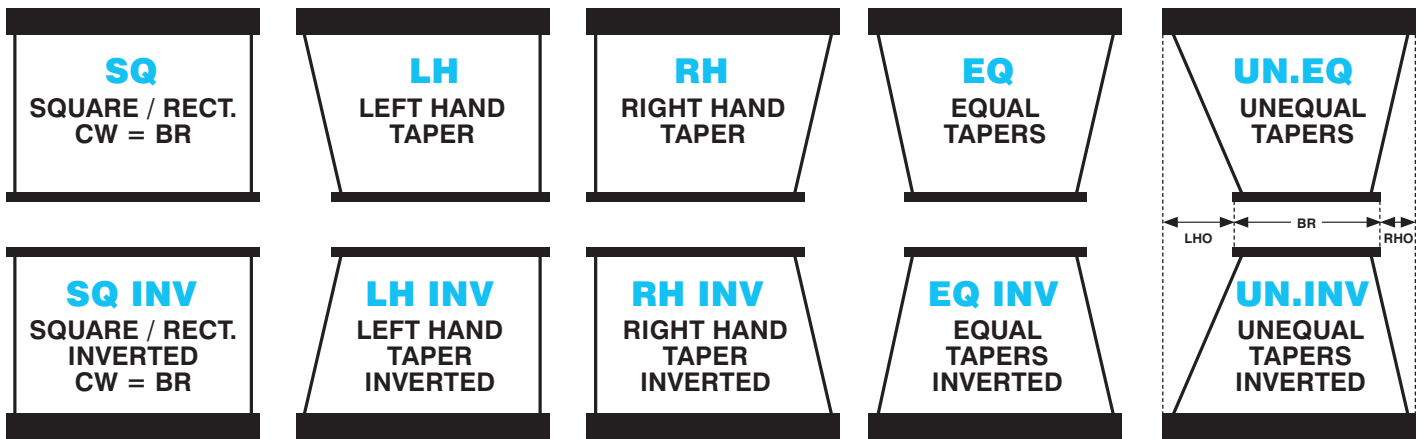

TRAPEZIUM / RHOMBOID / PARALLELOGRAM SHAPED WINDOWS



Where space at the top of the window is limited, an area of glass 'A' would not be covered by the film/fabric.



Where space at the top allows the roller/cassette to be extended then the extra width of film/fabric allows all of the glass to be covered.

CASSETTE

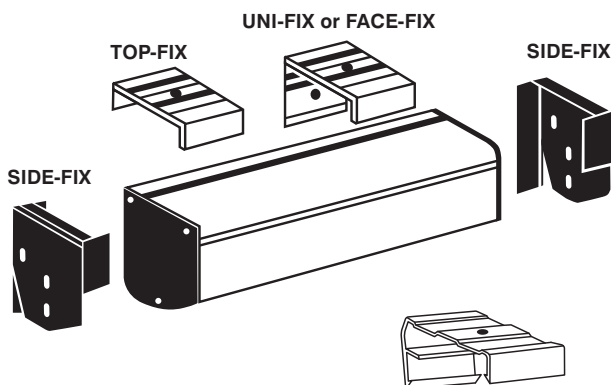

NON-CASSETTE

UNI-FIX

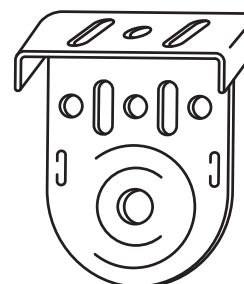

Please Note:
Angled brackets can be used if necessary and are available on request

Operating Systems

NOTE: Extra guide pulleys, clam cleats and cord can be supplied for more remote applications.

ROLLER OPERATING MECHANISMS:

- S/L SPRING = Self Lock Spring
- C/T SPRING = Constant Tension Spring - Centre Pull
- D/P SPRING = Constant Tension Spring - Double Pulley Bottom Rail
- L/H CLUTCH = Left Hand Chain Operated Clutch
- R/H CLUTCH = Right Hand Chain Operated Clutch
- ELECTRIC = Mains Power or Low Voltage Motors
- STOPLITE = Blackout Blind with Double Side Channels
- VARYSTOP = Room Darkening Blind with Single Side Channels

Please Note:

Clam Cleats are supplied as standard.

Push buttons are available on request.

Clam Cleat



Push Button



DOUBLE PULLEY BOTTOM RAIL CONSTANT TENSION SPRING OPERATION

Ideal For Sloping Windows

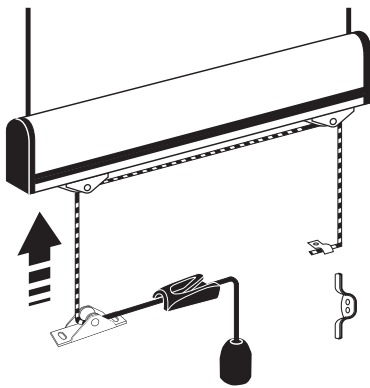

CONSTANT TENSION SPRING - CENTRE PULL OPERATION

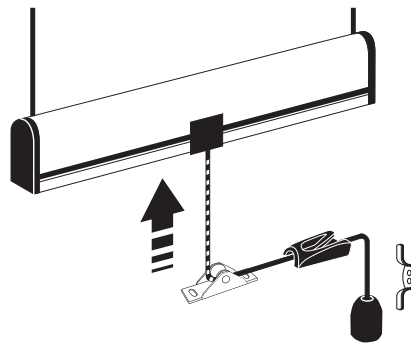

SELF LOCK SPRING OPERATION

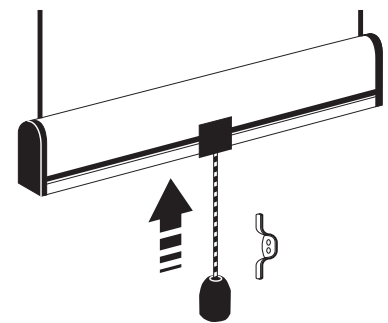

L/H CLUTCH - CHAIN OPERATION (R/H ALSO AVAILABLE)

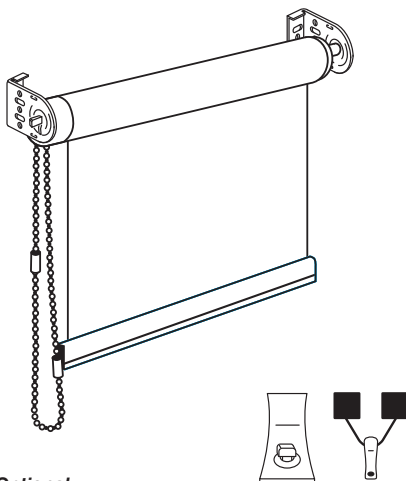

Optional:

- Leather Tabs & Turnbuttons

- Hook & Loop

CENTRAL RELEASE MECHANISM

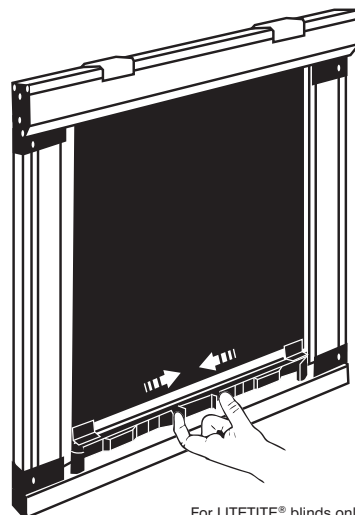

For LITETITE® blinds only.

ELECTRIC OPERATION

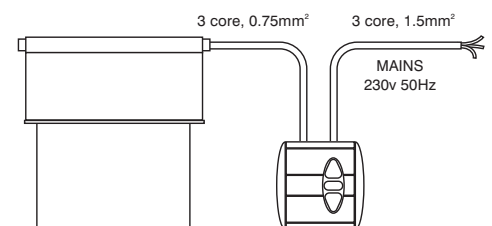

Important: We suggest Uni-Fix brackets for inverted screen installations.

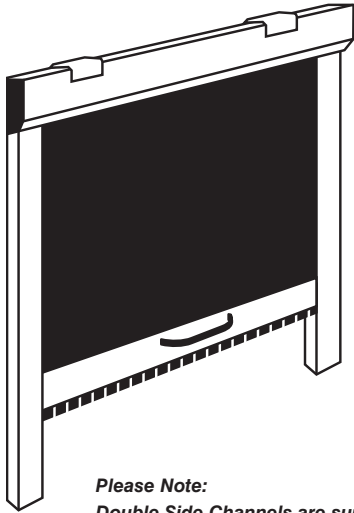

Please Note:
Double Side Channels are supplied.

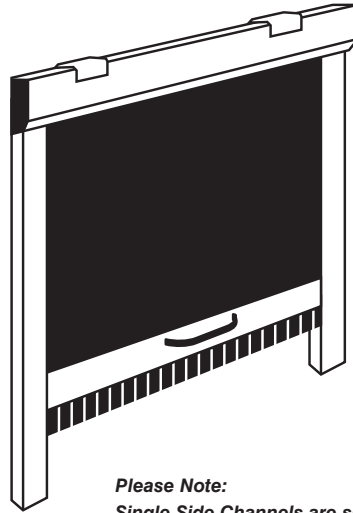

Please Note:
Single Side Channels are supplied.

Double Pulley Bottom Rail Operating System

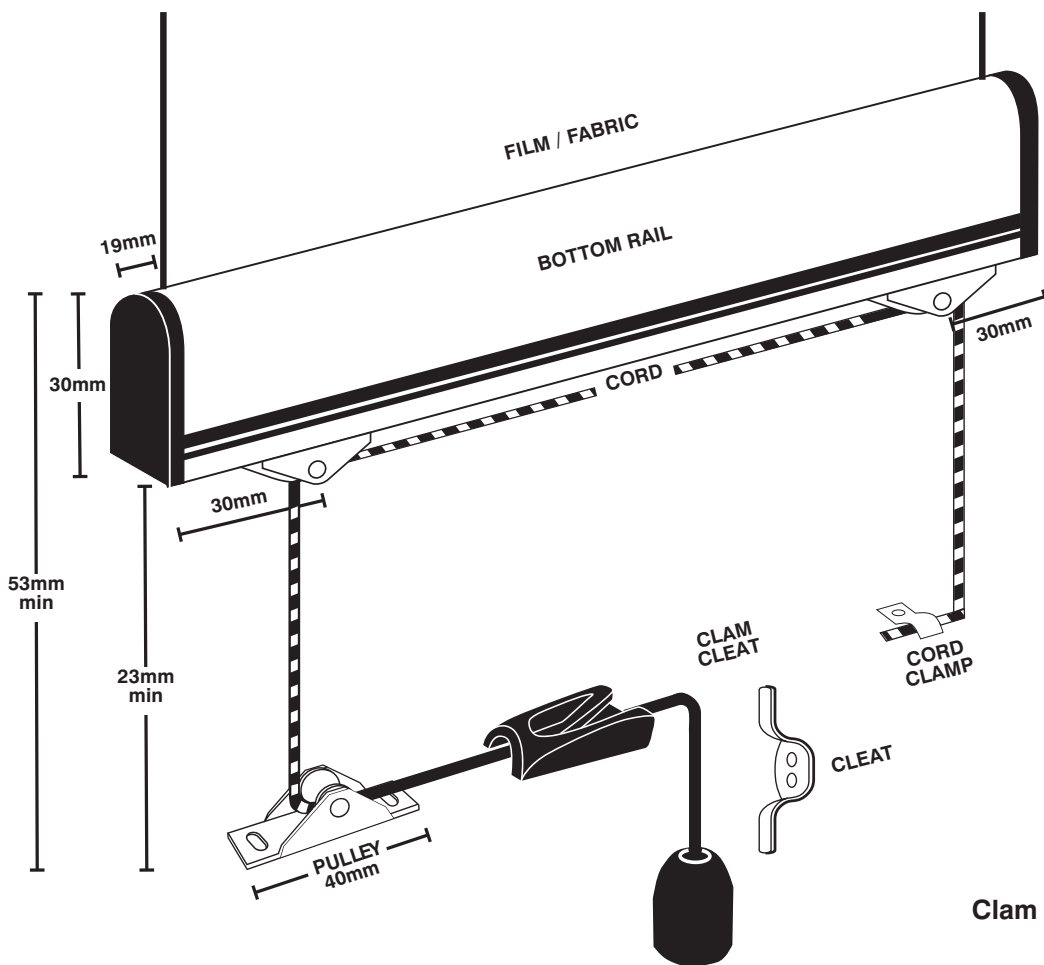

Please Note:
Clam Cleats are supplied as standard.
Push buttons are available on request.

Clam Cleat



Push Button

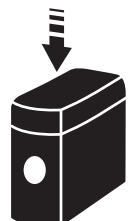

Aluminium Profile Data

Please Note: All dimensions are in mm.

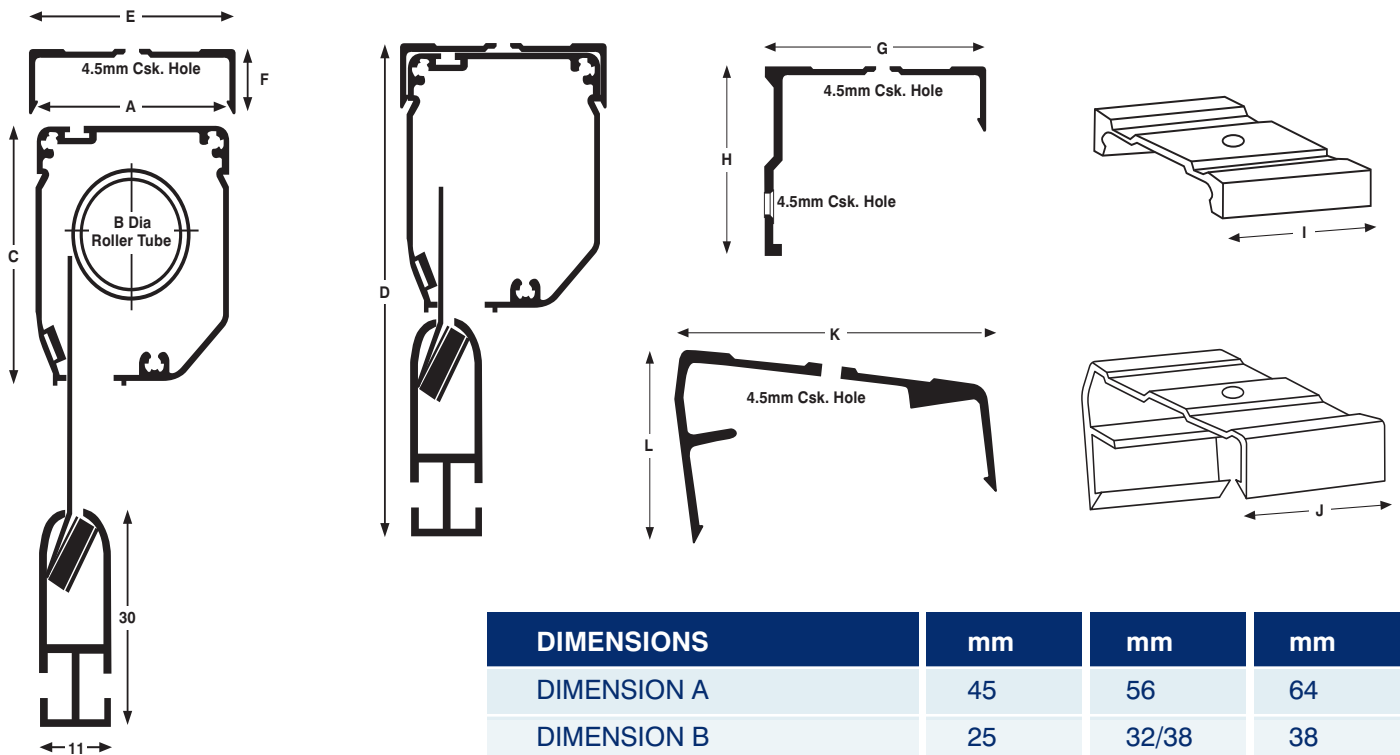

The information in the table shown opposite refers to the cassette systems and associated aluminium profiles used in the manufacture of SOLASOLV® cassette mounted sunscreens and roller blinds.

The aluminium profiles can be powder coated to most RAL standards. More than 400 colours are available in a choice of gloss, matt and satin finishes. Further details are available on request.

DIMENSIONS	mm	mm	mm
DIMENSION A	45	56	64
DIMENSION B	25	32/38	38
DIMENSION C	56	69	79
DIMENSION D	90	103	113
DIMENSION E	48	59	67
DIMENSION F	17	17	21
DIMENSION G	52	63	70
DIMENSION H	40	45	80
DIMENSION I	40	40	60
DIMENSION J	50	50	50
DIMENSION K	48	59	67
DIMENSION L	27	31	37
Spring Operation MIN width	350	385	530
Spring Operation MAX width	2,000	2,800	3,500
Clutch Operation MIN width	N/A	330	330
Clutch Operation MAX width	N/A	2,800	3,500
Low Volt Elec.Op. MIN width	500	N/A	N/A
Low Volt Elec.Op. MAX width	2,000	N/A	N/A
Low Volt Elec.Op. Dim B	29	N/A	N/A
230 Volt Elec.Op. MIN width	N/A	550	550
230 Volt Elec.Op. MAX width	N/A	2,800	3,000
230 Volt Elec.Op. Dim B	N/A	44	44
MINIMUM DROP	250	250	250
MAXIMUM DROP	2,000	2,250	3,500

Spare Parts List For Cassette Roller Blinds & Screens

- 1 Film / Fabric
- 2 Blackout Bottom Rail
- 3 Roll Tube - 25 / 32 / 38mm
- 4 Spring Mechanism - 25 / 38mm
- 5 Side Chain Clutch Mech. - 32 / 38mm
- 6 Roll Tube End Pin - 25 / 32 / 38mm
- 7 Bottom Rail
- 8 Aluminium Retaining Strip
- 9 DS Adhesive Tape
- 10 Bottom Rail End Cap
- 11 Pull Cord Holder
- 12 Side-Fix Bracket
- 13 Acorn
- 14 Stainless Steel Cleat
- 15 Pull Cord
- 16 Operating Bead Chain
- 17 Chain Connector
- 18 Chain Tensioner
- 19 Cassette Pin End Plate RH/LH
- 20 Uni-Fix Brackets
- 21 Top-Fix Brackets
- 22 Cassette
- 23 Brush Strip
- 24 End Plate Screws short/long
- 25 Inner Side Channel
- 26 Outer Side Channel
- 27 Rivet for LITETITE B.O. fabric
- 28 PVC Retaining Rod
- 29 Bottom Block
- 30 BOBR Slide
- 31 Bottom Slide Unlock Tabs
- 32 Bottom Slide with Latch
- 33 Connection Strip
- 34 Bottom Rail Handle
- 35 Bottom Moulding
- 36 Curtain Feed
- 37 Stainless Steel Cord Clamp
- 38 Stainless Steel Guide Pulley
- 39 Push Button
- 40 Cassette Cable Support Kit
- 41 Uni-Fix Adaptor Bracket
- 42 Adaptor Clamp
- 43 Adaptor Bolt
- 47 Spring End Plate
- 48 Clutch End Plate
- 49 Cable Guide
- 50 Clam Cleat
- 51 Hook and Loop
- 57 Leather Tabs and Turnbuttons

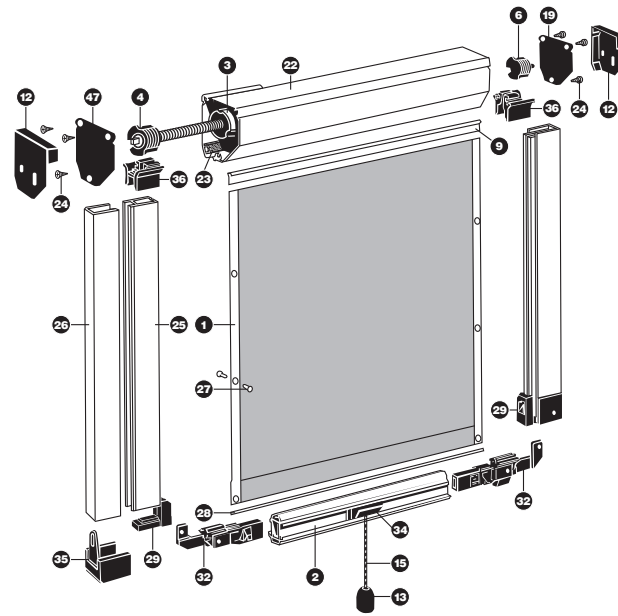

CASSETTE CABLE SUPPORT KIT

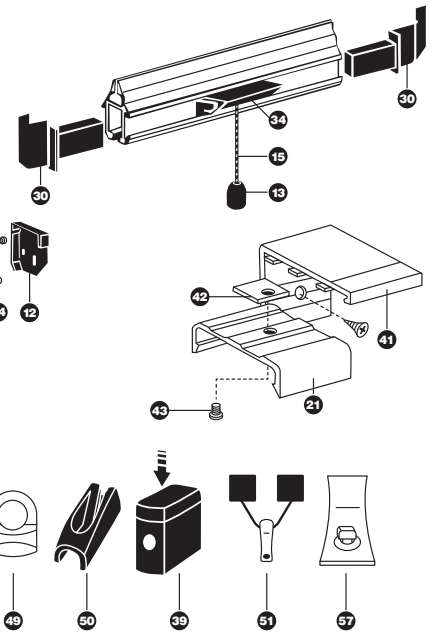
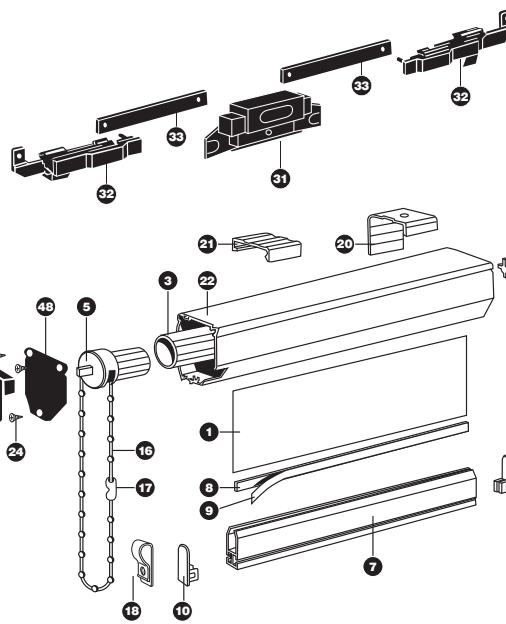
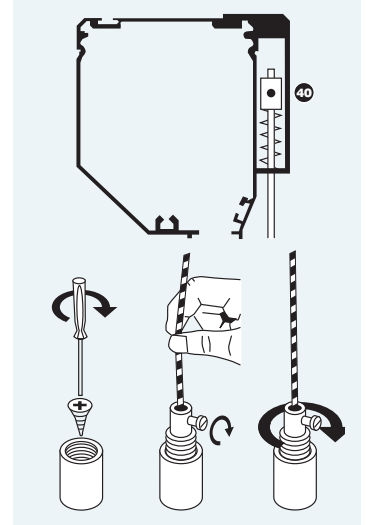

DOUBLE PULLEY BOTTOM RAIL CONSTANT TENSION SPRING OPERATION

Ideal For Sloping Windows

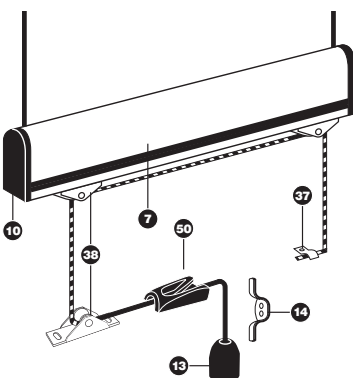

CONSTANT TENSION SPRING - CENTRE PULL OPERATION

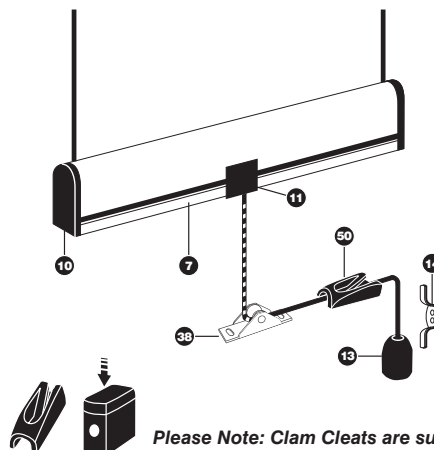

SELF LOCK SPRING OPERATION

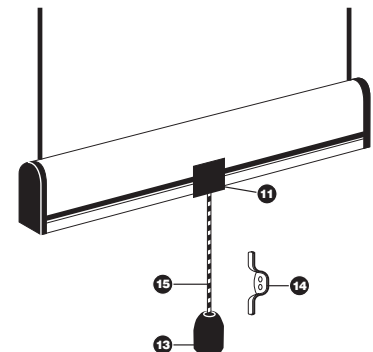

Please Note: Clam Cleats are supplied as standard. Push buttons are available on request.

Spare Parts List For Non-Cassette Roller Blinds & Screens

- 1 Film / Fabric
- 3 Roll Tube - 25 / 32 / 38mm
- 4 Spring Mechanism - 25 / 38mm
- 5 Side Chain Clutch Mech. - 32 / 38mm
- 6 Roll Tube End Pin - 25 / 32 / 38mm
- 7 Bottom Rail
- 8 Aluminium Retaining Strip
- 9 DS Adhesive Tape
- 10 Bottom Rail End Cap
- 11 Pull Cord Holder
- 13 Acorn
- 14 Stainless Steel Cleat
- 15 Pull Cord
- 16 Bead Operating Chain
- 17 Chain Connector
- 18 Chain Tensioner
- 26 Outer Side Guide Channel
- 37 Stainless Steel Cord Clamp
- 38 Stainless Steel Guide Pulley
- 39 Push Button
- 46 Non-Cassette Cable Support Kit
- 49 Cable Guide
- 50 Clam Cleat
- 51 Hook and Loop
- 52 Spring Uni-fix Bracket 25 / 38mm
- 53 Pin End Uni-fix Bracket 25 / 38mm
- 54 Clutch Pin End Uni-fix Bracket 32 / 38mm
- 55 Pin End Uni-fix Bracket 32 / 38mm
- 56 Bracket Covers
- 57 Leather Tabs and Turnbuttons

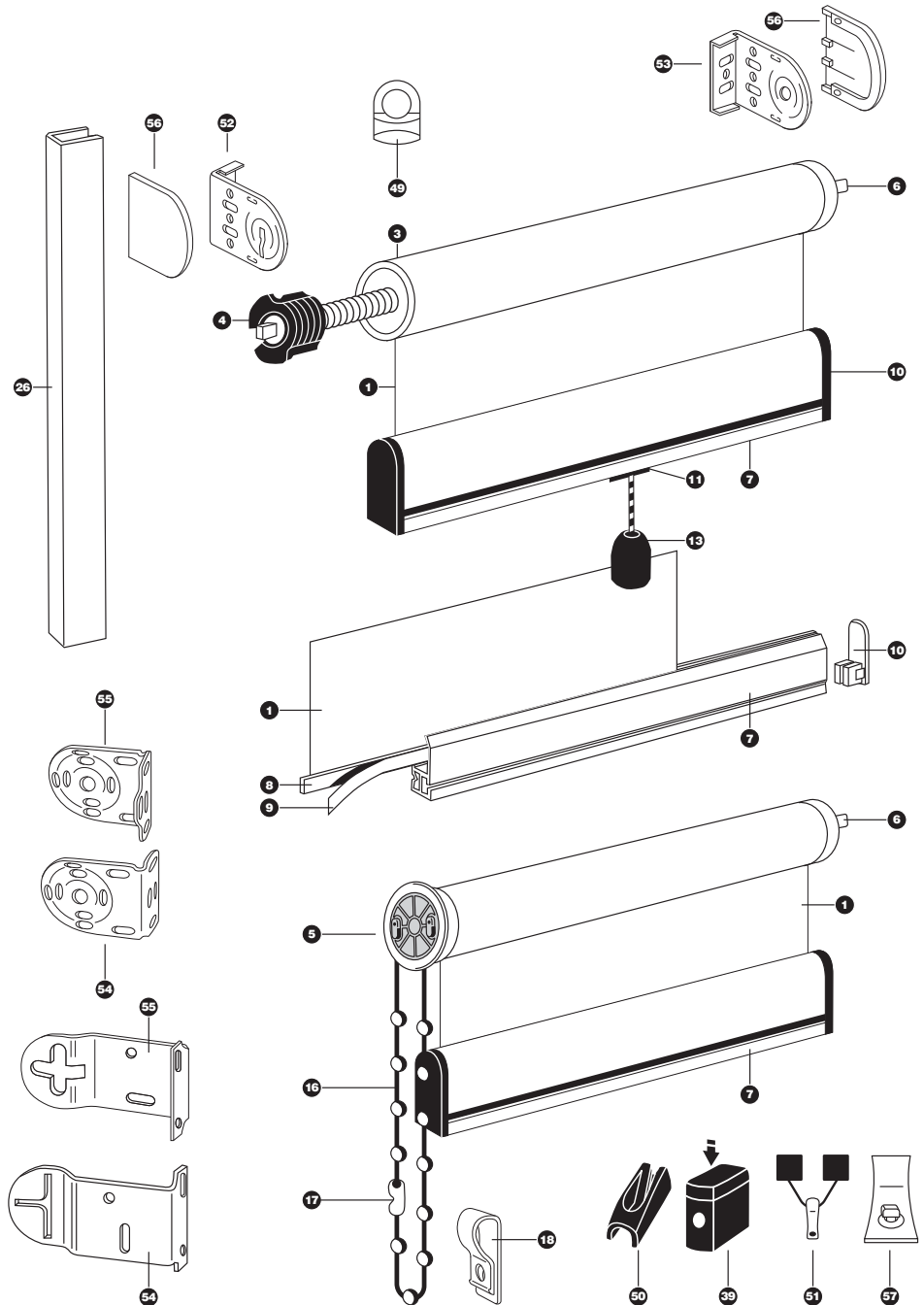

NON-CASSETTE CABLE SUPPORT KIT

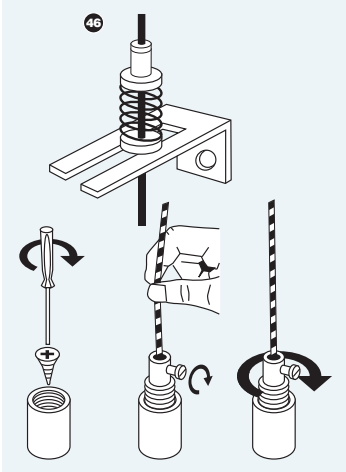

DOUBLE PULLEY BOTTOM RAIL CONSTANT TENSION SPRING OPERATION

Ideal For Sloping Windows

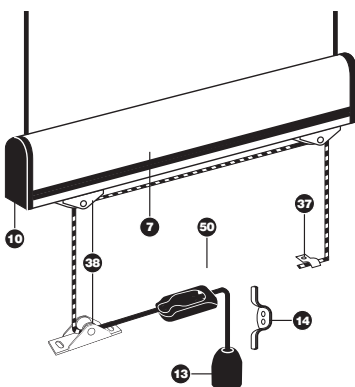

CONSTANT TENSION SPRING - CENTRE PULL OPERATION

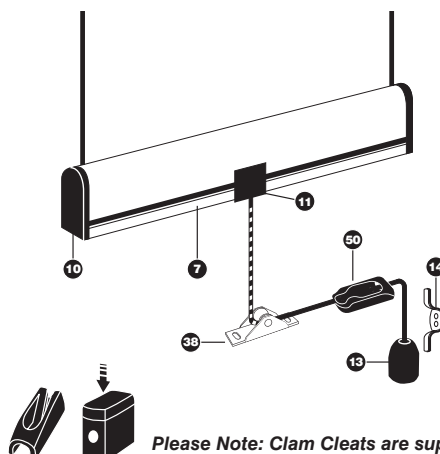

SELF LOCK SPRING OPERATION

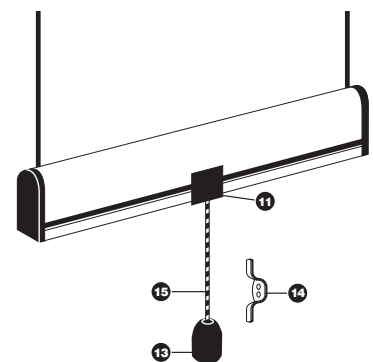

Please Note: Clam Cleats are supplied as standard. Push buttons are available on request.

SOLASOLV® Anti-Glare Roller Screen Installation

NORMAL METHOD OF INSTALLATION FOR WINDOWS OF ANGLES UP TO 15° FROM THE VERTICAL

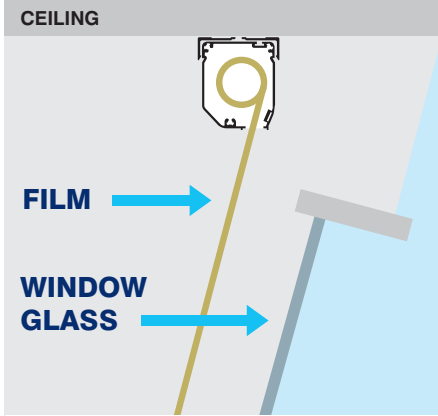

ALTERNATIVE METHOD OF INSTALLATION

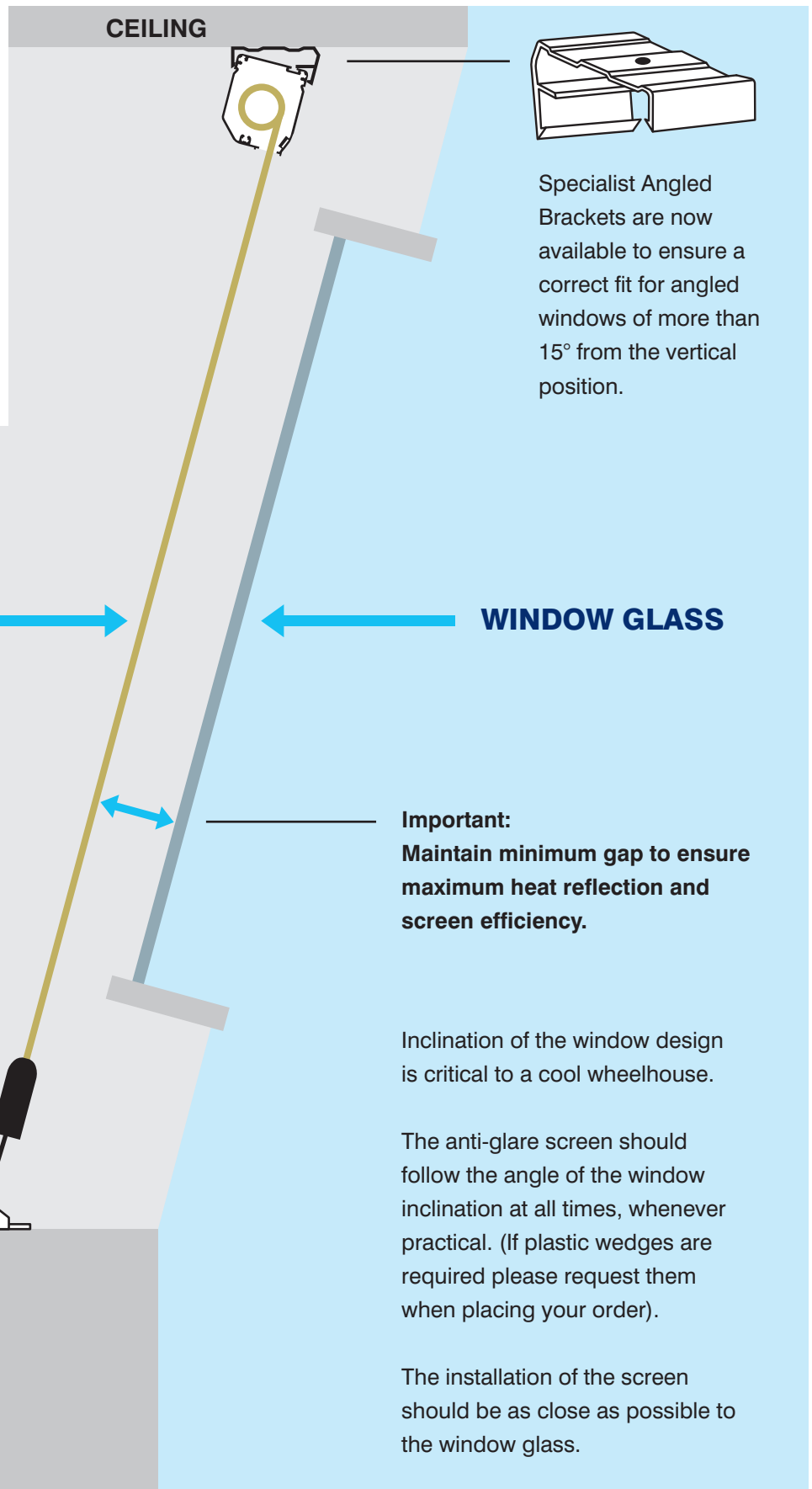

Installation of Cassette Mounted Blinds & Screens

CASSETTE INSTALLATION

Decide **EXACTLY** where the screen / blind is to be fitted, ensuring that:

- The screen / blind will not interfere with window handles or any other obstructions, when operated.
- The screen is absolutely level.

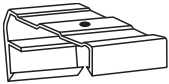
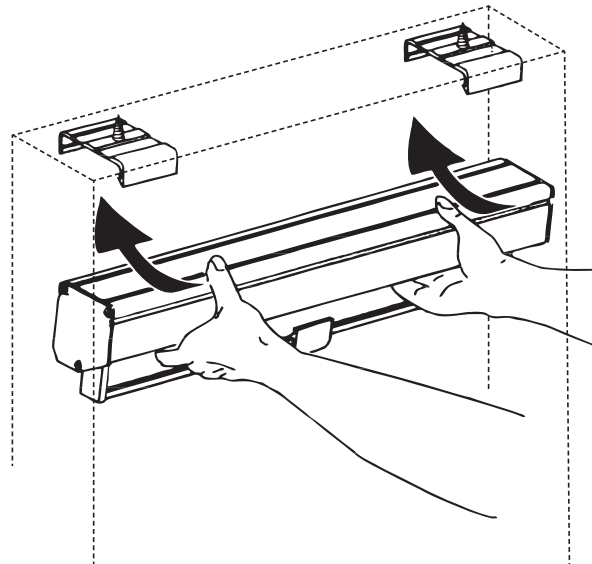
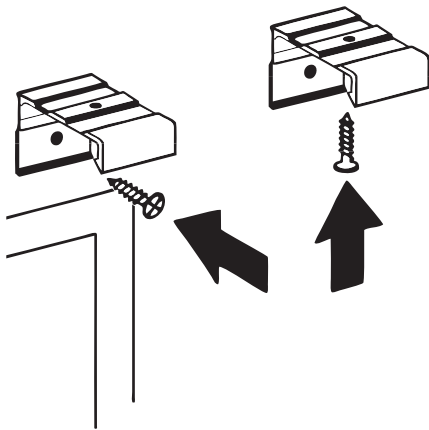

Please Note:
Angled brackets can be used if necessary and are available on request

CABLE SUPPORT SYSTEM

Completed cable system as seen from behind screen.

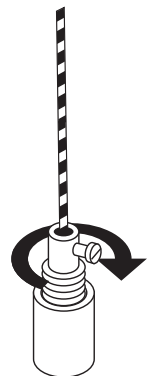
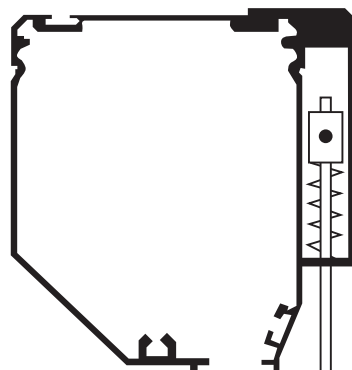
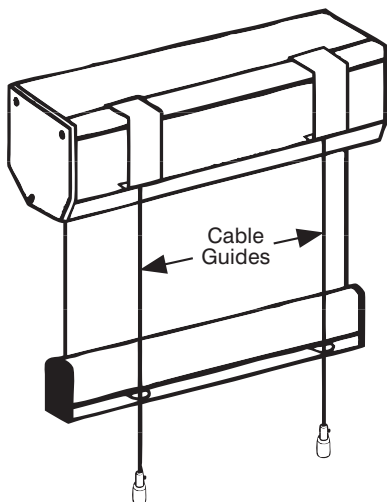

Installation of Cassette Mounted Blinds & Screens

LITETITE BLACKOUT BLIND INSTALLATION (INSIDE RECESS)

Decide **EXACTLY** where the screen / blind is to be fitted, ensuring that:

- The screen / blind will not interfere with window handles or any other obstructions, when operated.
- The screen is absolutely level.

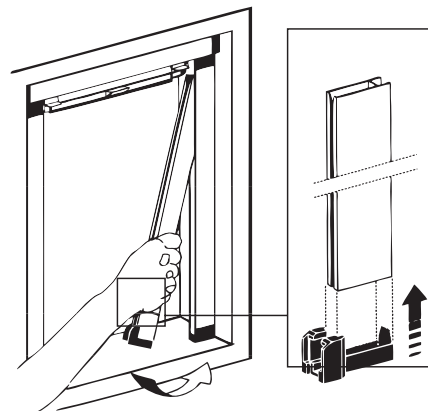
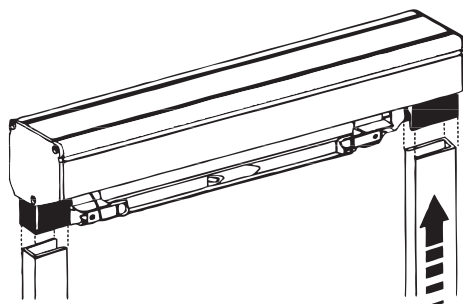

*Please note:
For LITETITE®
outside recess
installations fitting
instructions will be
provided with the
order.*

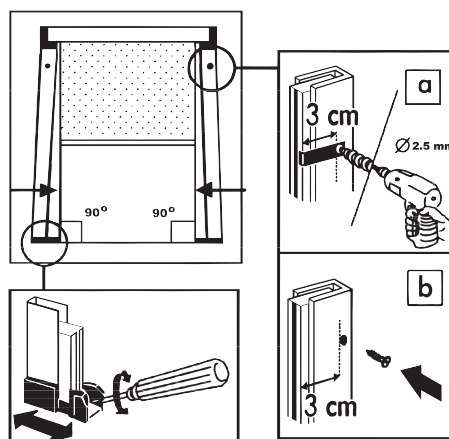
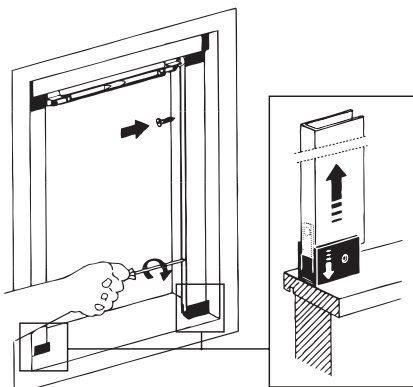

CASSETTE MOUNTED ELECTRICALLY MOTORISED ROLLER BLINDS/SCREENS

1. Decide **EXACTLY** where the screen / blind is to be fitted, ensuring that:

- The screen / blind will not interfere with window handles or any other obstructions, when operated.
- The screen is absolutely level.

2. Mark off the position of the fixing holes and drill pilot hole.

3. Secure the brackets with the 30mm x 4mm self tapping screws provided.

4. Push-fit the cassette securely into the brackets.

5. If the screen is to be fitted with a Cable Guide system, refer to the cassette mounted fitting instructions.

UNI-FIX or FACE-FIX

TOP-FIX



SIDE-FIX

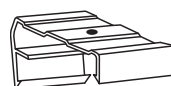
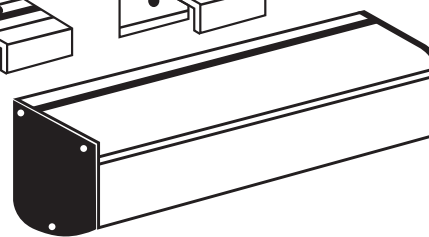

*Please Note:
Angled brackets can be used if necessary
and are available on request.*

Installation of Non-Cassette Mounted Blinds & Screens

BRACKET POSITIONS

Decide **EXACTLY** where the screen / blind is to be fitted, ensuring that:

- The screen / blind will not interfere with window handles or any other obstructions, when operated.
- The screen is absolutely level.
- The brackets are fixed securely.

Important: Always use the gloves provided when handling film

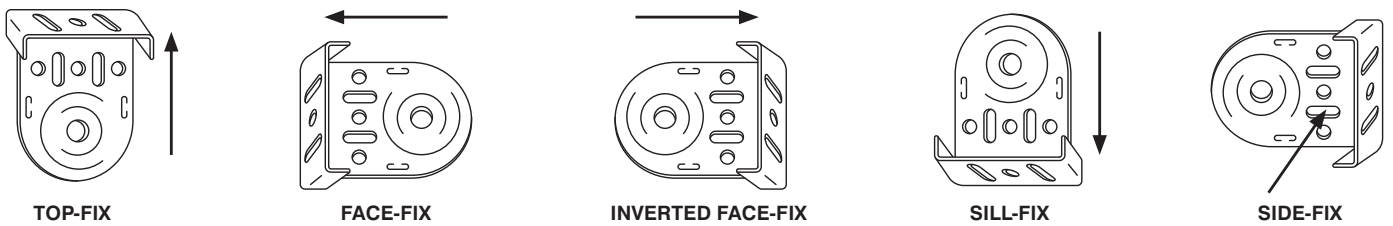

INSTALLATION INSTRUCTIONS FOR SCREENS/BLINDS WITH CONSTANT TENSION SPRINGS

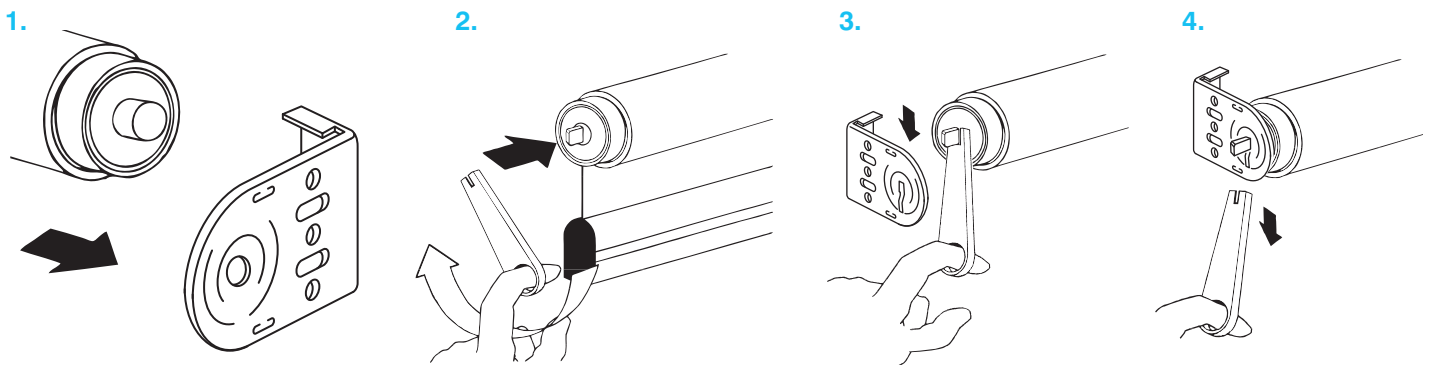

Please Note:

To increase or decrease spring tension see chart on page 16.

INSTALLATION INSTRUCTIONS FOR SCREENS/BLINDS WITH SELF LOCK SPRINGS

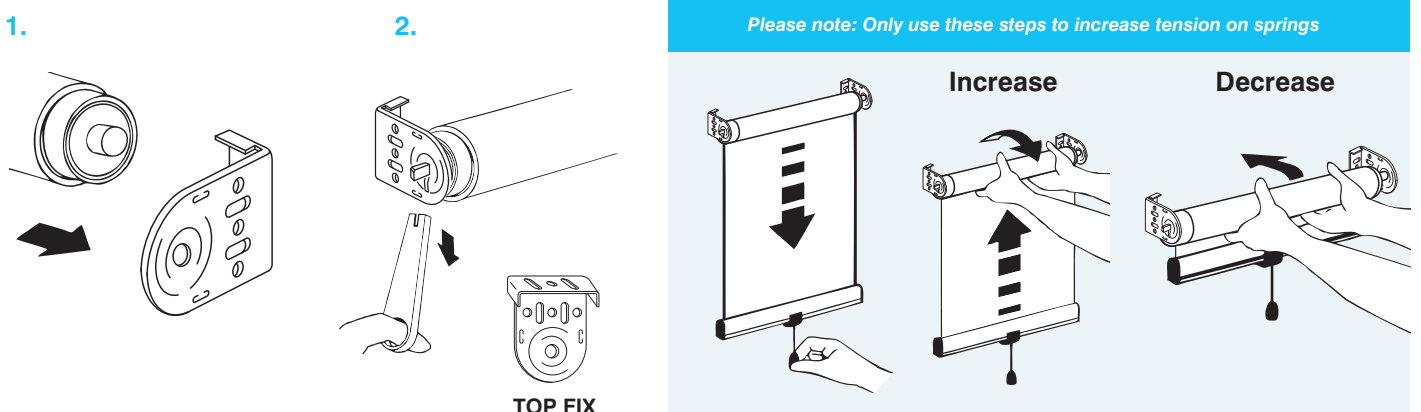

Installation of Non-Cassette Mounted Blinds & Screens

CABLE SUPPORT SYSTEM

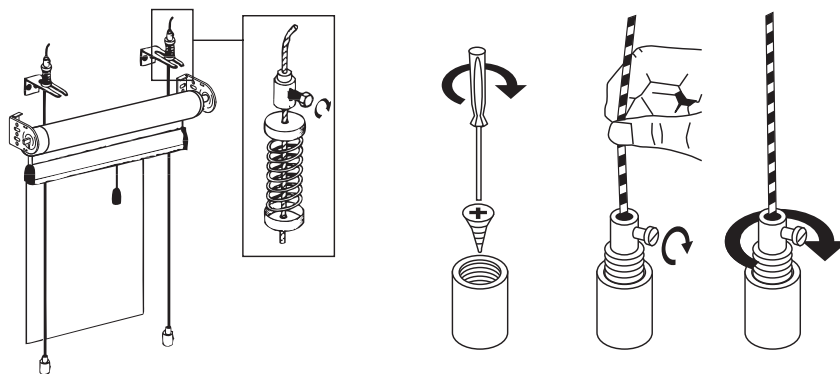

NON-CASSETTE SPRING TENSIONING GUIDE - NUMBER OF TURNS ON SPRING

SPRING	1000mm	1200mm	1400mm	1600mm	1800mm	2000mm
25mm 3kg	14	16	18	20	22	24
25mm 4.5kg	8	10	12	14	15	16
SPRING	2000mm	2200mm	2400mm	2600mm	2800mm	3000mm
38mm 3kg	20	22	24	26	28	30
38mm 5kg	10	11	12	13	14	15

Please note: The above chart is only a guide and additional turns may need to be applied if the screen or blind does not retract correctly (especially in the case of DIMMLITE fabric blinds). If the screen or blind retracts too quickly then fewer turns may be needed than shown above.

JOIN

The film and fabric we use in the manufacture of our screens/blinds are supplied in standard roll widths (Maximum Film Width 1,829mm and Maximum Fabric Width 3,200mm depending on type). If a screen or blind is ordered with a width and drop greater than the maximum roll width then a horizontal join will be required in the film/fabric.

MAXIMUM CASSETTE SIZE

The maximum cassette width we recommend is 3,500mm. The reason for this is that the roll tube over this distance has a tendency to sag in the middle due to the weight of the film/fabric. This sag causes the roll tube to rotate in an elliptical manner, which in turn causes the film to hit the back of the cassette. Each time the film touches the back of the cassette it scratches and over a period of time it becomes difficult to see clearly through the film.

NON-CASSETTE ELECTRICALLY MOTORISED BLINDS & SCREENS

The brackets supplied are UNI-FIX and are suited to all methods of fitting. TOP, FACE, SIDE.

Decide exactly where the screen is to be fitted ensuring that:

- the screen will not interfere with window handles or other obstructions when the screen is operated.
- the screen is absolutely level.

Mark off the fixing holes and fit the brackets using the 3.5 x 20mm self tap screws provided.

Complete the installation by wiring up to the switch and then the power supply by referring to the wiring diagram supplied.

For mains motors, adjust the 'STOP' positions using the Allen Key provided. For low voltage motors, use a terminal screwdriver to set the 'STOP'. It does not matter which side the motor is fitted to as the same adjusters set the same 'STOP' positions.

MAINS MOTOR

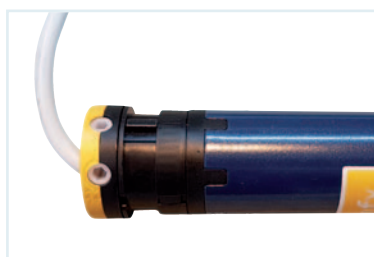

LOW VOLTAGE MOTOR



Electrical Operation

ELECTRICAL OPERATION

All roller screens and blinds can be electrically operated either individually or in groups and from a position nearby or remotely at some distance from the installation. Electrical operation is particularly suitable where access is difficult.

LOW VOLTAGE (12V or 24V DC)

Is available for screens from 500mm to 2000mm wide.

MAINS VOLTAGE (230V 50Hz or 60Hz)

Is available for screens from 550mm to 3000mm wide. The simplest and most economical method of control is via a locally situated 3-position rocker switch to control each screen individually. Alternatively the rocker switches could be located on a console enabling remote individual control.

Where screens are required to be operated in groups, they can be operated from one central work station or they can have remote group AND local individual operation. They can also be operated by hand held remote control. (See opposite and below).

Further technical information regarding electrically operated installations and a wiring design service is available from Solar Solve Ltd.

ELECTRICAL SCREENS DISCLAIMER

Due to the size of the motors used in the manufacture of our screens it may mean that the usual gap of 19mm (between the overall cassette width and film width), on each side of the screen, may have to be increased slightly to prevent damage to the film.

SWITCHES



REMOTE CONTROL HANDSETS SINGLE AND GROUP CONTROL



EXAMPLES OF VARIOUS METHODS OF ELECTRICAL INSTALLATION

DC POWERED SCREENS

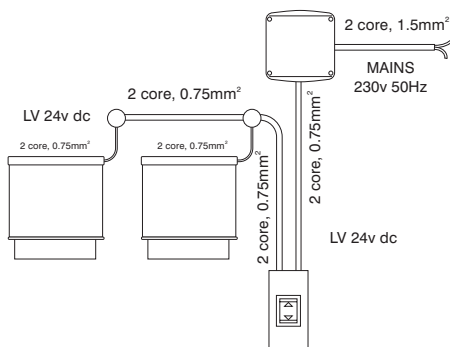

RTS RADIO CONTROL (DC)

Please Note:
Not suitable for
ATC Towers.

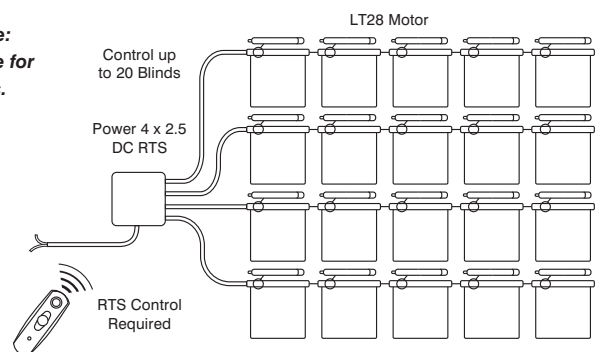

AC POWERED SCREENS

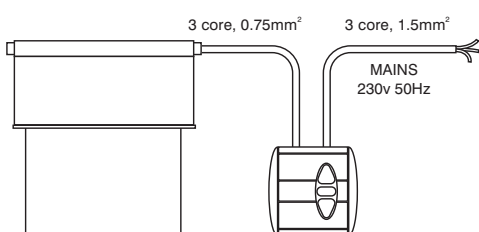

RTS RADIO CONTROL (AC)

Please Note:
Not suitable for
ATC Towers.

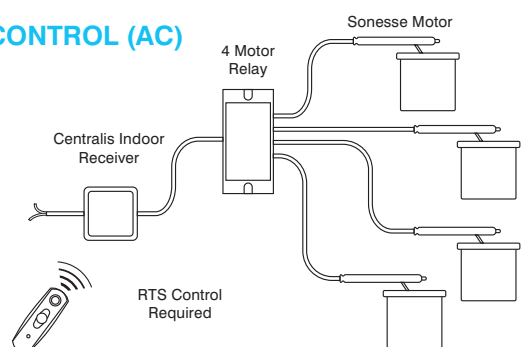

For safer navigation



SOLAR SOLVE
THE ANTI-GLARE EXPERTS



Solar Solve Limited

7 Waldrige Way | Simonside East Industrial Park | South Shields | Tyne and Wear | NE34 9PZ | UK

Tel: +44 (0) 191 454 8595 | **Email:** info@solasolv.com | **www.solasolv.com**