

ELECTRO-TYFON® MT 150/140

For vessels of 75 m to 200 m in length

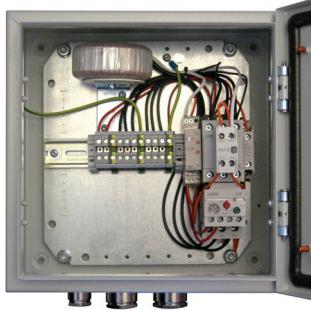

Contactor Unit TK 80
See separate leaflet KSM742

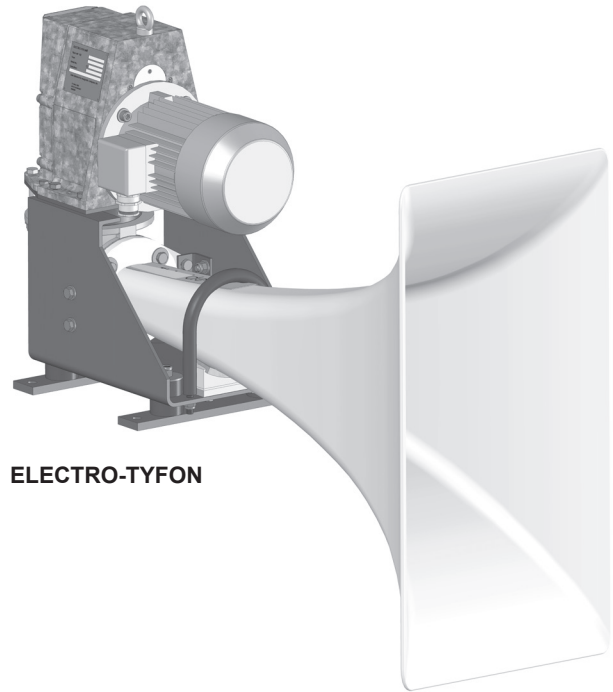

ELECTRO-TYFON

General Information

ELECTRO-TYFON® MT 150/140 is an electrically driven piston ship's whistle. It is built up of comparatively few moving parts as the "swinging piston", no lubricated cylinder and an oil free gearbox.

Important features:

- unsymmetrical sound distribution
- operates in all ambient temperatures without any additional measures
- unaffected by voltage and frequency fluctuations
- oil free, maintenance free and non-corrosive
- easy to install
- complies fully with the International Regulations IMO 1972

Operates in all temperatures without any additional measures

ELECTRO-TYFON® MT 150/140 will give a high performance in both arctic and tropical climates. A patented system with a high efficiency rectangular horn and a specially designed motor will match the motor speed to the acoustic resonance of the horn at any ambient temperature without any additional measures. This system also prevents the whistle from being affected by voltage and frequency fluctuations in onboard mains.

Unsymmetrical Sound Distribution

The IMO Regulations stipulate a very high Sound Pressure Level for efficient signaling, yet the sound level of the vessel's own signal at the listening posts shall not exceed 110 dBA.

A common way to solve this "paradox" is to place the whistle very high above deck. But what if the highest point is not high enough? For example: to reduce the noise from the signal by 6 dB, the distance between the listening post and the whistle must be doubled!

ELECTRO-TYFON® MT 150/140 with Unsymmetrical Sound Distribution is the solution. The horn with its unique vertically extended front, and a specially created sound spectrum will reduce the noise on deck with 6–8 dB compared to a conventional whistle with circular outlet.

Technical Data

Type	Power Supply	Ref No
MT 150/140	3 ph 380-440 V 60 Hz	24800569
MT 150/140	3 ph 380-440 V 50 Hz	24800570
MT 150/140	3 ph 660-690 V 60 Hz	24800571
MT 150/140	3 ph 660-690 V 50 Hz	24800572

Sound frequency (basic):	140 Hz
Sound Pressure Level acc to IMO (1/3 oct band):	>138 dB/1m
Sound Level A-weighted:	142 dBA/1m
Rated current:	9A / 440V at 20°C 7A / 690V at 20°C
Electrical protection class:	IP 56
Colors:	
Body	Galvanized nat.
Motor	Grey RAL 7030
Horn	White RAL 9003
Weight (approx.):	68 kg

Motor Control

Kockum Sonic's Contactor Unit TK 80 is especially developed to control the **ELECTRO-TYFON® MT 150/140**

Functions:

- Motor start
- Motor overload protection
- Winding heating of motor for anti-condensation purpose.

For full description see data sheet KSM742.

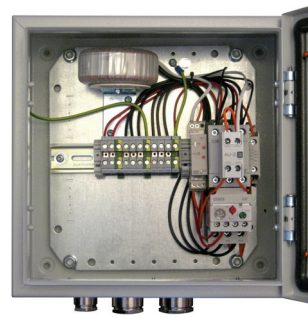

Dimensions, Installation and Maintenance

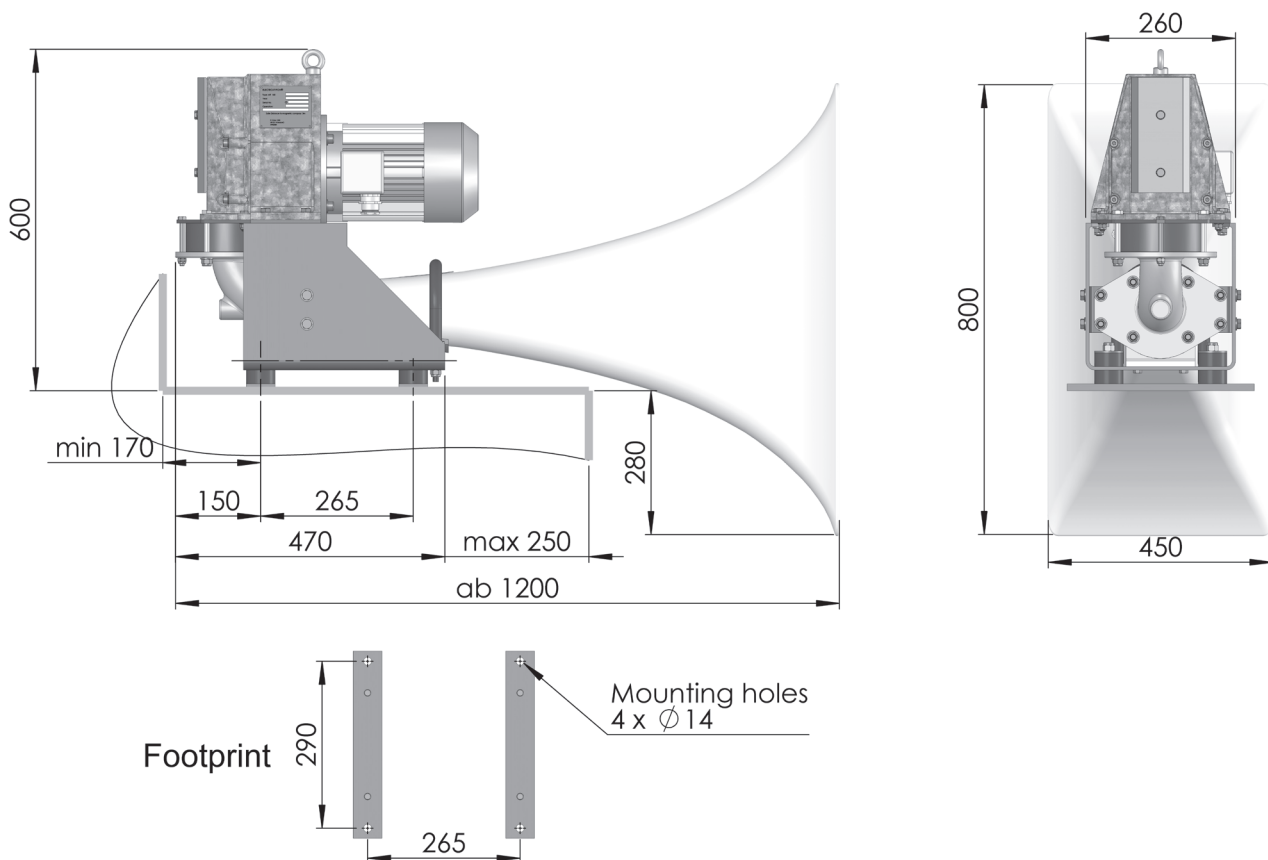

Installation

ELECTRO-TYFON® MT 150/140 shall be fixed with four M12 screws that must be firmly tightened and locked.

Mount the whistle on a platform supplied with a safety rail. As the whistle is subject to vibration on starting and stopping, flexible electric cables should be used nearest the motor. The gland on the electric Motor Terminal Box is M 32 for cable \varnothing 17 - 28 mm.

Optional: M 25 for cable \varnothing 9-20 mm.

Recommended power cable section:

For cable length up to 100 m \varnothing 4 mm²

For cable length over 100 m \varnothing 6 mm²

Recommended fuses slow 20A

Maintenance

All components are chosen to withstand corrosion and to give a minimum of maintenance.

The crankcase and foundation is hot galvanized. The motor is marine coated - Marine C4 class.

The horn is made of glass fiber armed polyester (white). The cylinder is non lubricated and the gearbox is entirely oil free.

ELECTRO-TYFON® MT 150/140 is designed to give long reliable service without routine maintenance, but a periodic inspection always gives early warning of any faults that may develop.

Trouble shooting and refurbishing

Trouble shooting, refurbishing

Prior to any work on the unit disconnect power.

Eliminate possible power failure; check the voltage of every phase on motor wire terminals.

Motor is not running	Check the wirings for possible shortcut or insulation error.	Change the motor together with the motor gearwheel.
Motor is running slow, Weak sound	Check the wirings for possible shortcut or insulation error.	If motor OK check and change, if required, the shaft with bearings.
Motor is running, only mechanical noise	Check the piston, piston rings and piston rod.	Change damaged components. It is not necessary to disassembly the motor.
Powerful vibration, entire unit	Check the vibration dampers.	Change if damaged

Important:

- The motor (driver) is always delivered with the driving gear wheel mounted on the shaft.
- Do not reuse the old gear wheel, it is made of bakelite and pressed with tight fit and may be damaged when removed/remounted.
- Lubricate the teeth of the gearwheels with the grease enclosed in the set.
- Change always piston and piston rod together. When loosening and retightening the piston screw counter hold with a spanner on the flat surfaces of the piston rod just above the piston to avoid twisting the rod.
- Lubricate the piston rod bearing and fill half of the volume inside the bearing cover with high-speed roller bearing grease enclosed in the set.
- The gear shaft as spare part is delivered complete with front bearing and gear wheel. Do not remove rear bearing if not necessary, it is fixed in the crank case.
- Do not reuse the steel gear wheel, it is warm pressed with very tight fit and may be damaged when removed/remounted.
- On inspection or change of parts, always replace O-rings, circlips, the piston rod sealing ring with new ones.
- Lock all screws with Loctite 242 or similar locking liquid.

In case of insecurity do not hesitate to contact Kockum Sonics for guidance.

Kockum Sonics can also carry out repair or deliver refurbished unit to a reduced price.

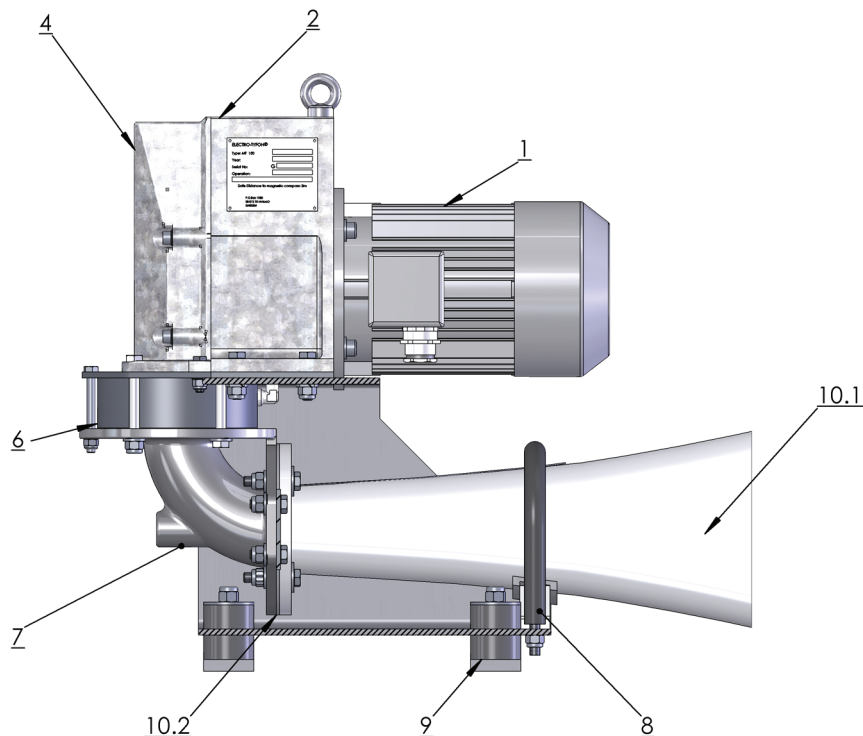

MT 150/140 - Parts list

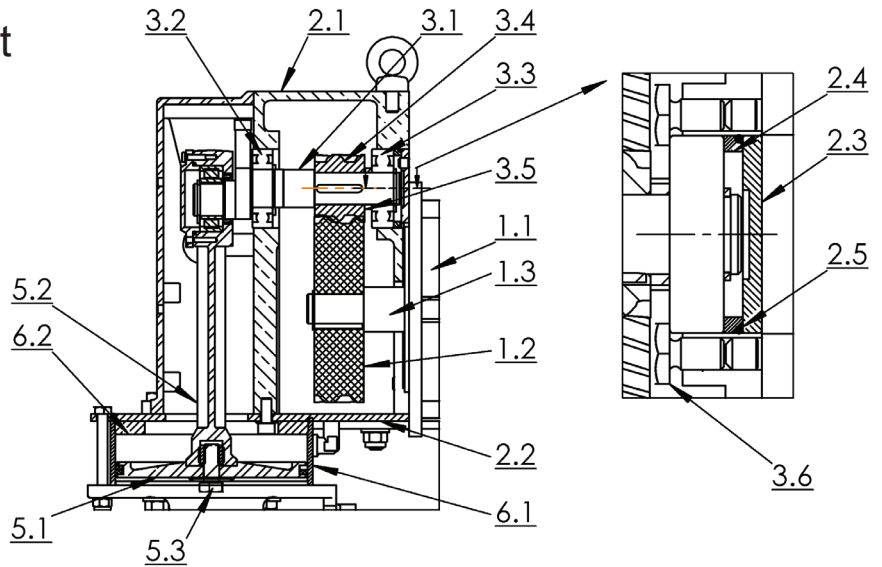

Item	Description	Data/remarks	Ref. No.
1	Driver		
1.1	Motor	380-440V/50-60Hz 660-690V/50-60Hz	21800321 21801029
1.2	Motor gear wheel	60Hz 50Hz	21768364 21768362
1.3	Spacer		21768373
1.4	Circlip	SMS 1581	32470024
1.5	Connection box	Incl. terminals	20750100
2	Crank case		
2.1	Housing		21769059
2.2	Base plate		21768365
2.3	Cap		21768399
2.4	Spacer		21768404
2.5	O-ring	57,6 x 2,4	20862066
3	Crank shaft		
3.1	Crank shaft set	Incl. Crankshaft flat key screws and circlips	24530292
3.2	Bearing front		20880005
3.3	Bearing rear		20880003
3.4	Gear wheel	60 Hz 50 Hz	21768359 21768357
3.5	Spacer		21768376
3.6	Fixing screw	2 pcs	21769060
4	Cover		21769059
5	Piston		
5.1	Piston set	Incl piston, rings (x2) , pin	24530296
5.2	Piston rod set	Incl rod, cap, nut, bearing, radial seal, O-ring, screws, washers, circlip	24530291
5.3	Piston mounting set	Washer, screw	24530297
6	Cylinder		
6.1	Cylinder		21768986
6.2	Flange		21768368
7	Outlet		21768984
8	Clamp set	Incl clamp, slang, support, spacer, rubberpacking	24530294
9	Vibration damper set	Incl dampers, bushings washers and nuts	24530293
10	Horn		
10.1	Horn		21750121
10.2	Packing		21765049